DESPIECE TECNICO

**Cocinas a Gas
Fourneaux à Gaz
Gas Ranges
Gas-Herde
Cucine a Gas
Fogões a Gás**

GAMA SNACK

Modelos:

CAG-20

CAG-30

CAG-21

CAG-31

Octubre 2010 October

rev 022022



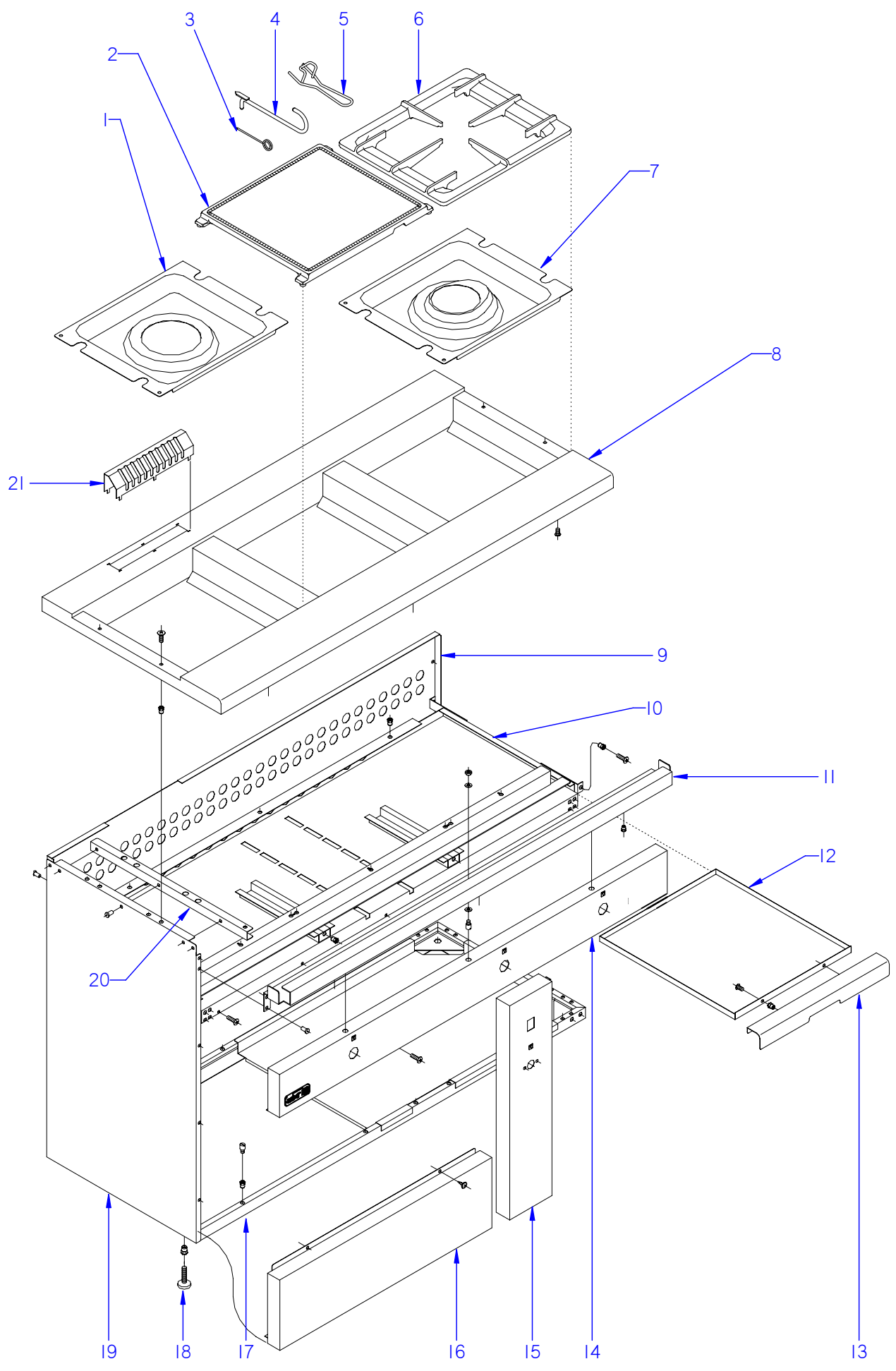

ITEM MARCADO EN COLOR = REPUESTO RECOMENDADO
 COLOURED ITEM = RECOMMENDED SPARE PART

N plano	Firma	Fecha	Aparato	MUEBLE / UNIT	Lamina	
C-2700	<i>[Signature]</i>	2010-10	COCINAS SNACK		1	

MOD.		COCINAS SNACK /SNACK RANGES		ZONA / ZONE	MUEBLE / UNIT				PLANO DIAGRAM	C-2700
ITEM	CODIGO CODE	DENOMINACION	NAME	CAG-20	CAG-30	CAG-21	CAG-31			
1	12038913	VERTEDERO 6000	DISCHARGE 6000	1	1	1	1		ELIMINADO 19.01.2015	
1	12005898	VERTEDERO 6000	DISCHARGE 6000	1	1	1	1		INTRODUCIDO 19.01.2015	
	Q152017000	TORNILLO AMARRE M6X13 A304	FASTENING SCREW M6X13 A304	4	4	4	4			
	Q419005000	REMACHE 4X8 ALMG3 / ALUMINIO	RIVET 4X8 ALMG3 / ALUMINIUM	2	2	2	2			
2	U565406000	PLACA	PLATE	1	1	1	1		ELIMINADO 15.04.2019	
2	12009499	PLACA	PLATE	1	1	1	1		INTRODUCIDO 15.04.2019	
3	623500000	AGUJA DE LIMPIEZA 08555	CLEANING NEEDLE 08555	1	1	1	1			
4	623600000	PALANCA LEVANTAPLACAS 06330	PLATE LIFT LEVER 06330			1	1			
5	U506501000	PALANCA LEVANTAPLACAS 17106	PLATE LIFT LEVER 17106	1	1	1	1			
6	U565403000	PARRILLA ESMALTADA	ENAMELLED GRILLE	1	2	1	2			
7	12038914	VERTEDERO 4000	DISCHARGE 4000		1		1		ELIMINADO 19.01.2015	
7	12120850	VERTEDERO 4000	DISCHARGE 4000		1		1		INTRODUCIDO 19.01.2015	
8	U535430000	MESA COMPLETA	COMPLETE TABLE	1						
8	U525430000	MESA COMPLETA	COMPLETE TABLE		1					
8	U515430000	MESA COMPLETA	COMPLETE TABLE			1				
8	U505430000	MESA COMPLETA	COMPLETE TABLE				1			
9	U532831000	PANEL POSTERIOR -200	REAR PANEL -200	1						
9	U522834000	PANEL POSTERIOR -300	REAR PANEL -300		1					
9	U512802000	PANEL POSTERIOR -210	REAR PANEL -210			1				
9	U502802000	PANEL POSTERIOR -310	REAR PANEL -310				1			
10	U502623000	BASE BANDEJA 200	TRAY BASE 200	1					ELIMINADO 08.04.2013	
10	12048855	BASE BANDEJA CG200	TRAY BASE CG200	1					INTRODUCIDO 08.04.2013	
10	U505455000	BASE BANDEJA 300	TRAY BASE 300		1				ELIMINADO 08.04.2013	
10	12048872	BASE BANDEJA CG300	TRAY BASE CG300		1				INTRODUCIDO 08.04.2013	
10	U502621000	BASE BANDEJA 210	TRAY BASE 210			1			ELIMINADO 08.04.2013	
10	12048861	BASE BANDEJA CG210	TRAY BASE CG210			1			INTRODUCIDO 08.04.2013	
10	U505454000	BASE BANDEJA 310	TRAY BASE 310				1		ELIMINADO 08.04.2013	
10	12048866	BASE BANDEJA CG-310	TRAY BASE CG-310				1		INTRODUCIDO 08.04.2013	
11	U512653000	TIRANTE FIJ PORTAMAND 210/200	CONTROL HOLDER FAST. TIE RC	1		1				
11	U502666000	TIRANTE FIJ PORTAMAND 310/300	CONTROL HOLDER FAST. TIE RC		1		1			

MOD.		COCINAS SNACK /SNACK RANGES		ZONA / ZONE		MUEBLE / UNIT				PLANO DIAGRAM		C-2700	
ITEM	CODIGO CODE	DENOMINACION	NAME	CAG-20	CAG-30	CAG-21	CAG-31						
12	U502610000	BANDEJA RECOGE GRASAS	GREASE COLLECTION TRAY	2	3	2	3						ELIMINADO 18,06,12
12	12045659	BANDEJA RECOGE GRASAS	GREASE COLLECTION TRAY	2	3	2	3						INTRODUCIDO 18,06,12
13	U502635000	ASA DE BANDEJA	TRAY HANDLE	2	3								
13	U502636000	ASA DE BANDEJA	TRAY HANDLE			2	3						
	Q221343000	REMACHE EXAGONAL M6	HEXAGONAL RIVET M6	4	4	4	4						
14	U532832000	PANEL PORTAMANDOS CG-200	CONTROL HOLDER PANEL 200	1									
14	U522842000	PANEL PORTAMANDOS CG-300	CONTROL HOLDER PANEL 300		1								
14	U512852000	PANEL PORTAMANDOS CG-210	CONTROL HOLDER PANEL 210			1							
14	U502853000	PANEL PORTAMANDOS CG-310	CONTROL HOLDER PANEL 310				1						
	Q152004000	TORNIL. APLASTADO M5X13 A 304	FLAT HEADED SCREW M5x13 A 304	2	2	2	2						
	Q232040000	ARANDELA A6	WASHER A6	2	2	2	2						
	U262833000	SELLO ASBER	ASBER EMBLEM	1	1	1	1						
	Q221023000	CLIP SUJECIÓN RÁPIDA Ø5	RAPID CONNECT CLIP Ø5	2	2	2	2						
15	U512865000	PANEL ANTERIOR LATERAL	FRONT SIDE PANEL			1							
15	U502864000	PANEL ANT.CENTRAL GRILL CG310	FRONT CENTRAL PANEL GRILL C				1						
16	U502835000	PANEL EXT. ANTERIOR INFERIOR	FRONT LOWER EXT. PANEL			1	1						
	Q151301000	PHILIPS 8X5/8	PHILIPS 8X5/8			2	2						
17	U502619000	ZOCALO 210	SKIRTING 210			1							
17	U502617000	ZOCALO 310	SKIRTING 310				1						
	Q221343000	REMACHE EXAGONAL M6	HEXAGONAL RIVET M6			4	6						
	Q151336000	TORNILLO SOPORTE GUIAS	GUIDE SUPPORT BOLT			2	2						
18	Z200107000	PATA REGULABLE	ADJUSTABLE LEG	4	4	4	4						
	Q221345000	REMACHE EXAGONAL M.10	HEXAGONAL RIVET M.10	4	4	4	4						
19	U522850000	PANEL LATERAL	SIDE PANEL	2	2								
19	U512858000	PANEL LATERAL CG-210	SIDE PANEL CG-210			1							
19	U502846000	PANEL LATERAL CG-310	SIDE PANEL CG-310			1	2						
	Q221343000	REMACHE EXAGONAL M6	HEXAGONAL RIVET M6	4	4	4	4						
	Q221026000	CLIP SUJECIÓN RÁPIDA Ø4	RAPID CONNECT CLIP Ø4	2	2	2	2						
20	U502645000	REFUERZO SUPERIOR	UPPER REINFORCEMENT			2	2						
	Q221342000	REMACHE EXAGONAL M5	HEXAGONAL RIVET M5			2	2						
21	U505410000	EMBELLECEDOR CHIMENEA G-310	FLUE TRIM G-310			1	1						

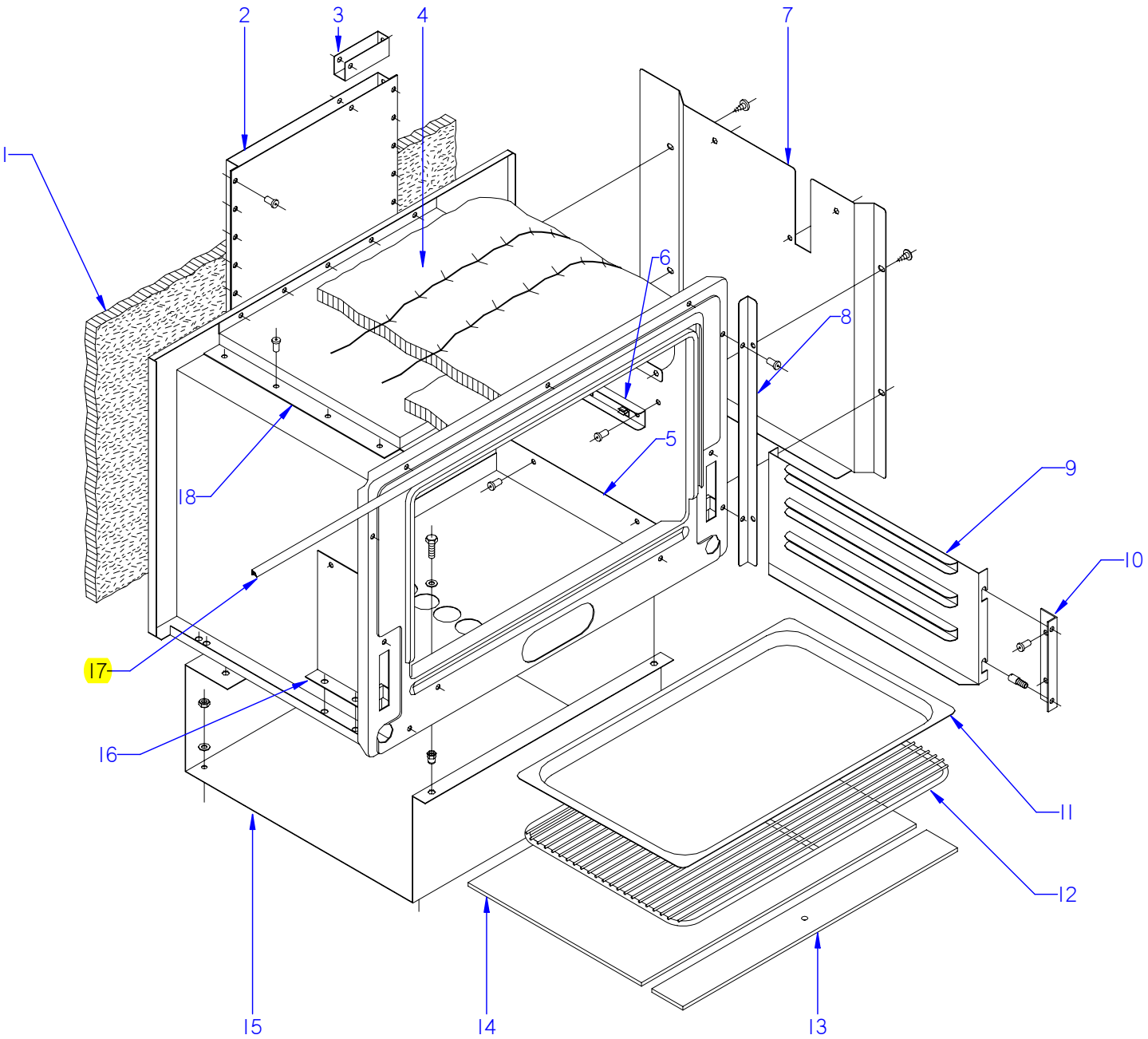

ITEM MARCADO EN COLOR = REPUESTO RECOMENDADO
 COLOURED ITEM = RECOMMENDED SPARE PART

N plano
 C-2701
 Firma
 Fecha
 2010-10
 Aparato

HORNO / OVEN
 COCINAS SNACK

Lamina
 2



MOD.		COCINAS SNACK /SNACK RANGES		ZONA / ZONE		HORNO / OVEN				PLANO DIAGRAM		C-2701	
ITEM	CODIGO CODE	DENOMINACION	NAME	CAG-21	CAG-31							NOTAS	
S/Nº	U505638000	HORNO COMPLETO INOX.	COMPL. OVEN INOX.	1	1								
1	U325622000	AISLANTE 700x460	INSULATION 700x460	2	2								
2	U505615000	POSTERIOR DE CHIMENEA-310	FLUEPIPE REAR-310	1	1								
S/Nº	U505614000	ANTERIOR DE CHIMENEA-310	FLUEPIPE FRONT-310	11	11								
	Q419005000	REMACHE 4X8 ALMG3 / ALUMINIO	RIVET 4X8 ALMG3 / ALUMINIUM	12	12								
	Q081365000	TOR. ALOMADO 4,8X19 H.ZINCADO	CURVED SCREW 4.8X19 H.ZINC	5	5								
3	U505619000	CHAPA REDUC. SALIDA GASES	GAS OUTPUT REDUC. PLATE	1	1								
4	U855620000	AISL. VITROFIB 1455X420X20AL1C	VITROFIB INS. 1455X420X20AL1C	1	1								
5	U505605000	BASE DE HORNO -310	OVEN BASE -310	1	1								
6	U055644000	CONJUNTO FIJACION BULBO	BULB FASTENING UNIT	1	1								
	Q151301000	PHILIPS 8X5/8	PHILIPS 8X5/8	2	2								
7	U502668000	CHAPA TAPA LATERAL HORNO	OVEN SIDE COVER PLATE	1	1								
	Q081365000	TOR. ALOMADO 4,8X19 H.ZINCADO	CURVED SCREW 4.8X19 H.ZINC	4	4								
8	U502810000	ESCUADRA CENTRAL VERTICAL	CENTRAL VERTICAL BRACKET	-	1								
	Q419005000	REMACHE 4X8 ALMG3 / ALUMINIO	RIVET 4X8 ALMG3 / ALUMINIUM	-	2								
9	U505639000	GUIA BANDEJA CAFETERIA	COFFEE MACHINE TRAY GUIDE	2	2								
10	U325611000	ESC.GUIA SOPORTE BANDEJAS	TRAY SUPPORT GUIDE BRACKET	2	2								
	Q419005000	REMACHE 4X8 ALMG3 / ALUMINIO	RIVET 4X8 ALMG3 / ALUMINIUM	4	4								
	Q151336000	TORNILLO SOPORTE GUIAS	GUIDE SUPPORT BOLT	4	4								
11	R252816000	BANDEJA 1/1 P:20	TRAY 1/1 P:20	1	1								
12	U015631000	PARRILLA DE HORNO	OVEN TRAY	1	1								
13	U505618500	CABEZA PLACA HORNO MECANZ	MACHINED OVEN PLATE HEAD	1	1								
14	U505617000	PLACA DE HORNO	OVEN PLATE	1	1								
15	U505640000	CALZO HORNO CAFETERIA	COFFEE MACHINE OVEN WEDGE	1	1							ELIMINADO 08.04.2013	
15	12048835	SOPORTE-HORNO-POSTERIOR	BACK-OVEN SUPPORT	1	1							INTRODUCIDO 08.04.2013	
	Q012031000	TORNILLO EXAGONAL M5X10	HEXAGONAL BOLT M5x10	4	4								
	Q221342000	REMACHE EXAGONAL M5	HEXAGONAL RIVET M5	2	2								
16	U325610000	CHAPA PROTECCION AISLANTE "	INSULATION PROTECTION PLATE	2	2								
	Q151301000	PHILIPS 8X5/8	PHILIPS 8X5/8	4	4								
17	U025623000	JUNTA PUERTA HORNO INOX	OVEN DOOR SEAL INOX.	1	1								
18	U505612000	CAMARA CONDUCC. HUMOS-310	SMOKE PIPE CHAMBER-310	1	1								

N plano	Firma	Fecha	Aparato	Lamina
C-2702		2010-10	COCINAS SNACK	3

PUERTAS / DOORS
ITEM MARCADO EN COLOR = REPUESTO RECOMENDADO
COLOURED ITEM = RECOMMENDED SPARE PART

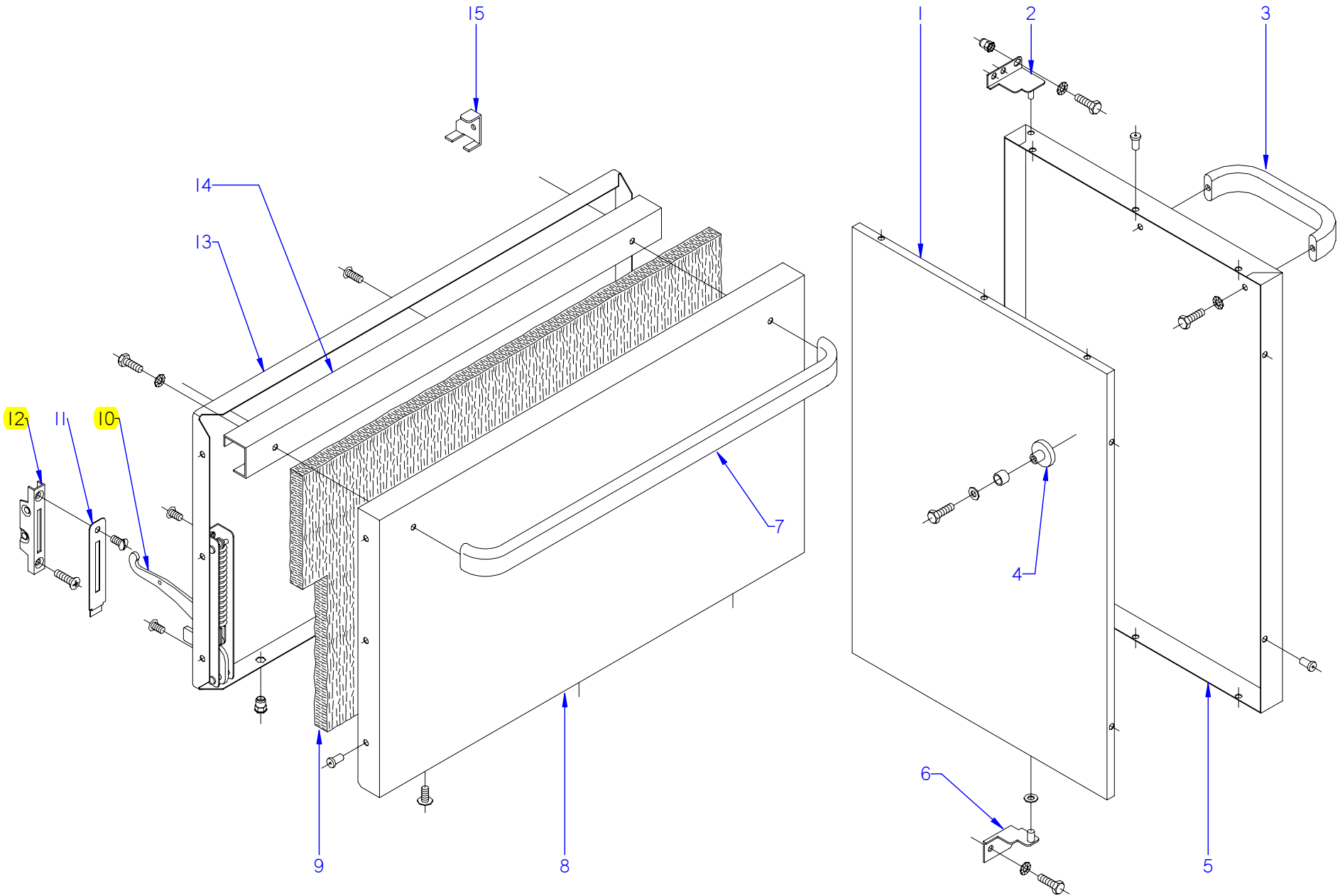

MOD.		COCINAS SNACK /SNACK RANGES		ZONA / ZONE		PUERTAS / DOORS				PLANO DIAGRAM		C-2702	
ITEM	CODIGO CODE	DENOMINACION	NAME	CAG-21	CAG-31							NOTAS	
1	U500545000	CONTRAPUERTA DE PORTABOMB.	CAN. HOLDER DOOR REVERSE.		1								
2	U500541000	BISAGRA SUPERIOR COMPLETA	COMPLETE UPPER HINGE		1								
	Q012031000	TORN.EXA. M5X10 A.304	HEX BOLT M5X10 A.304		3								
3	Z400542000	ASA LVS	HANDLE LVS		1								
	Q012041000	TORNILLO EXAGONAL M6X10	HEXAGONAL BOLT M6x10		2								
	Q242040000	ARANDELA ABANICO A6 A.304	FAN WASHER A6 A.304		2								
4	X960501000	IMAN	MAGNET		2								
	X960502000	FIJACION IMAN	MAGNET ATTACHMENT		2								
	Q012021000	TORN.EXA. M4X10	HEX BOLT M4X10		2								
	Q232020000	ARANDELA A-4	WASHER A-4		2								
5	U260508000	PUERTA DE PORTABOMBONAS	CAN.HOLDER DOOR		1								
	Q419005000	REMACHE 4X8 ALMG3 / ALUMINIO	RIVET 4X8 ALMG3 / ALUMINIUM		6								
6	U500542000	BISAGRA INFERIOR COMPLETA	COMPLETE LOWER HINGE		1								
	Q012041000	TORNILLO EXAGONAL M6X10	HEXAGONAL BOLT M6x10		2								
	Q242040000	ARANDELA ABANICO A6 A.304	FAN WASHER A6 A.304		2								
	Q232040000	ARANDELA A6	WASHER A6		1								
7	Z720504000	ASA DE PUERTA	DOOR HANDLE	1	1								
	Q012041000	TORNILLO EXAGONAL M6X10	HEXAGONAL BOLT M6x10	2	2								
	Q242040000	ARANDELA ABANICO A6 A.304	FAN WASHER A6 A.304	2	2								
8	U260507000	PUERTA DE HORNO COC.CAFETE.	COFF.MACH. OVEN DOOR	1	1								
8	12038793	PUERTA DE HORNO ANGOLA	OVEN DOOR ANGOLA	1	1								FOR ANGOLA
	Q419005000	REMACHE 4X8 ALMG3 / ALUMINIO	RIVET 4X8 ALMG3 / ALUMINIUM	6	6								
9	U260502000	AISLANTE 680X380X20	INSULATION 680X380X20	1	1								
10	U020528000	BISAGRA CIERRE HORNO	OVEN LOCK HINGE	2	2								
	Q152022000	TORNILLO M.6X8	BOLT M.6X8	6	6								
11	U010510000	EMBELLECEDOR GUIA BISAGRA	HINGE GUIDE TRIM	2	2								
	Q152017000	TORNILLO AMARRE M6X13 A304	FASTENING BOLT M6X13 A304	2	2								
12	U010512000	GUIA DE BISAGRA	HINGE GUIDE	2	2								ELIMINADO 12,12,11
12	12041845	GUIA DE BISAGRA	HINGE GUIDE	2									INTRODUCIDO 12,12,11
	Q042043000	TORNILLO AVELLANADO M6X20	COUNTERSUNK BOLT M6x20	2	2								

ITEM MARCADO EN COLOR = REPUESTO RECOMENDADO
 COLOURED ITEM = RECOMMENDED SPARE PART

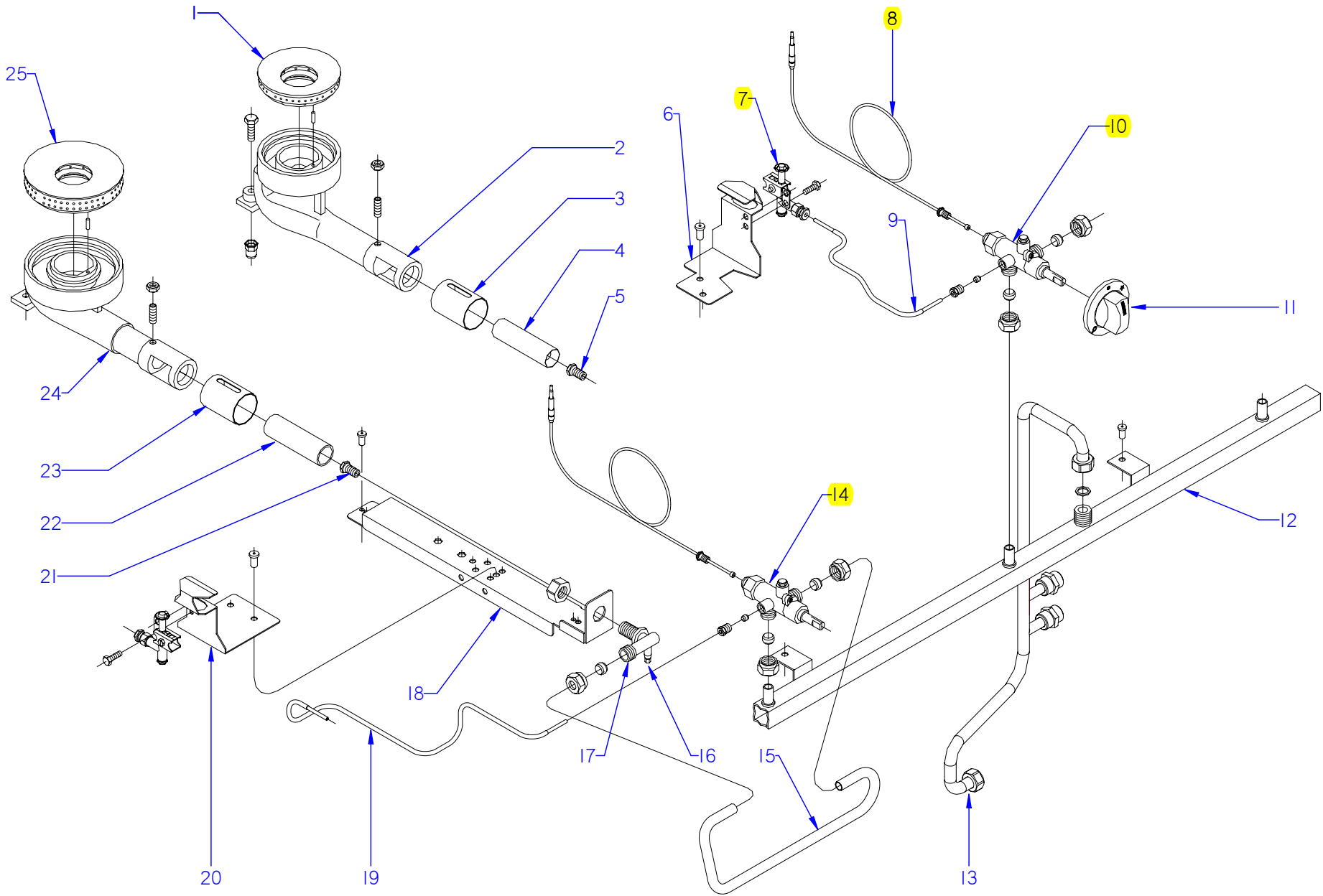

COCINAS SNACK /SNACK RANGES

ZONA / ZONE

CONJUNTO FUNCIONAL MESA
FUNCTIONAL SET TABLEPLANO
DIAGRAM

C-2703

ITEM	CODIGO CODE	DENOMINACION	NAME	CAG-20	CAG-30	CAG-21	CAG-31				
1	U445731000	QUEMADOR 4000 Kcal/H	BURNER 4000 Kcal/H	1	2	1	2				ELIMINADO 27,08,12
1	U445731500	QUEMADOR 4000 Kcal/H	BURNER 4000 Kcal/H	1	2	1	2				INTRODUCIDO 27,08,12
	Q371026000	MANGUITO SUJEC. 4X14 DIN1481	HOSE FASTENING 4X14 ØIN1481	1	2	1	2				
2	U445730000	CUERPO QUEMADOR 4000 011	BURNER BODY 4000 011	1	2	1	2				ELIMINADO 15.04.2019
2	12009498	CUERPO QUEMADOR 4000Kcal/H	BURNER BODY 4000Kcal/H	1	2	1	2				INTRODUCIDO 15.04.2019
3	U265702000	REGULADOR AIRE	AIR CONTROLLER	1	2	1	2				
4	U125720000	VENTURI QUEMADOR 4000 kcal	VENTURI BURNER 4000 kcal	1	2	1	2				
5	U122407000	TOBERA DE Ø 1.05 B.P.	NOZZLE Ø 1.05 B.P.	1	2	1	2				
5	9105100000	TOBERA DE Ø 1.50 G.N.	NOZZLE Ø 1.50 G.N.	1	2	1	2				
6	U505440000	SOPORTE PILOTO 4000	PILOT SUPPORT 4000	1	2	1	2				
7	11U4421340	PILOTO	PILOT	2	3	2	3				
	U442137000	INYECTOR Ø 0.4 GN	INJECTOR Ø 0.4 GN.	2	3	2	3				
	Q012021000	TORNILLO EXAGONAL M4X10	HEXAGONAL BOLT M4x10	4	6	4	6				
8	U222130000	TERMOPAR L=600	THERMOCOUPLE L=600	2	3	2	3				
9	U505042000	CONDUCCION PILOTO CONTROL	PILOT CONTROL PIPE	1	2	1	2				
	U195009000	MANGUITO EMPALME	CONNECTION HOSE	1	2	1	2				
	X205028000	BICONO Ø6	BICONE Ø6	1	2	1	2				
10	U249401000	GRIFO CAL 3200 0.55	HW TAP 3200 0.55	1	2	1	2				
	U055043000	BICONO Ø12	BICONE Ø12	4	6	4	6				
	Q221336000	TUERCA M18X1,5 Ø12	NUT M18X1.5 Ø12	2	3	2	3				
11	U502135000	BOTON DE MANDO Ø10	CONTROL BUTTON Ø10	2	3	2	3				
12	U515010000	CONDUCCION GENERAL 21	GENERAL PIPING 21	1		1					
12	U525032000	CONDUCCION GENERAL 30	GENERAL PIPING 30		1						
12	U505045000	CONDUCCION GENERAL 31	GENERAL PIPING 31				1				
	U505008000	TAPON 20X1 -310 EXT	COVER 20X1 -310 EXT	1	1	1	1				
13	U525031000	TUBO DISTRIBUIDOR	DISTRIBUTOR PIPE	1	1						
13	U515049000	TUBO DISTRIBUIDOR CG210	DISTRIBUTOR PIPE CG210			1					
13	U505082000	TUBO DISTRIBUIDOR CG310	DISTRIBUTOR PIPE CG310				1				
	U525003000	ANGULO PORTAGOMAS	RUBBER HOLDER BRACKET	1	2		2				

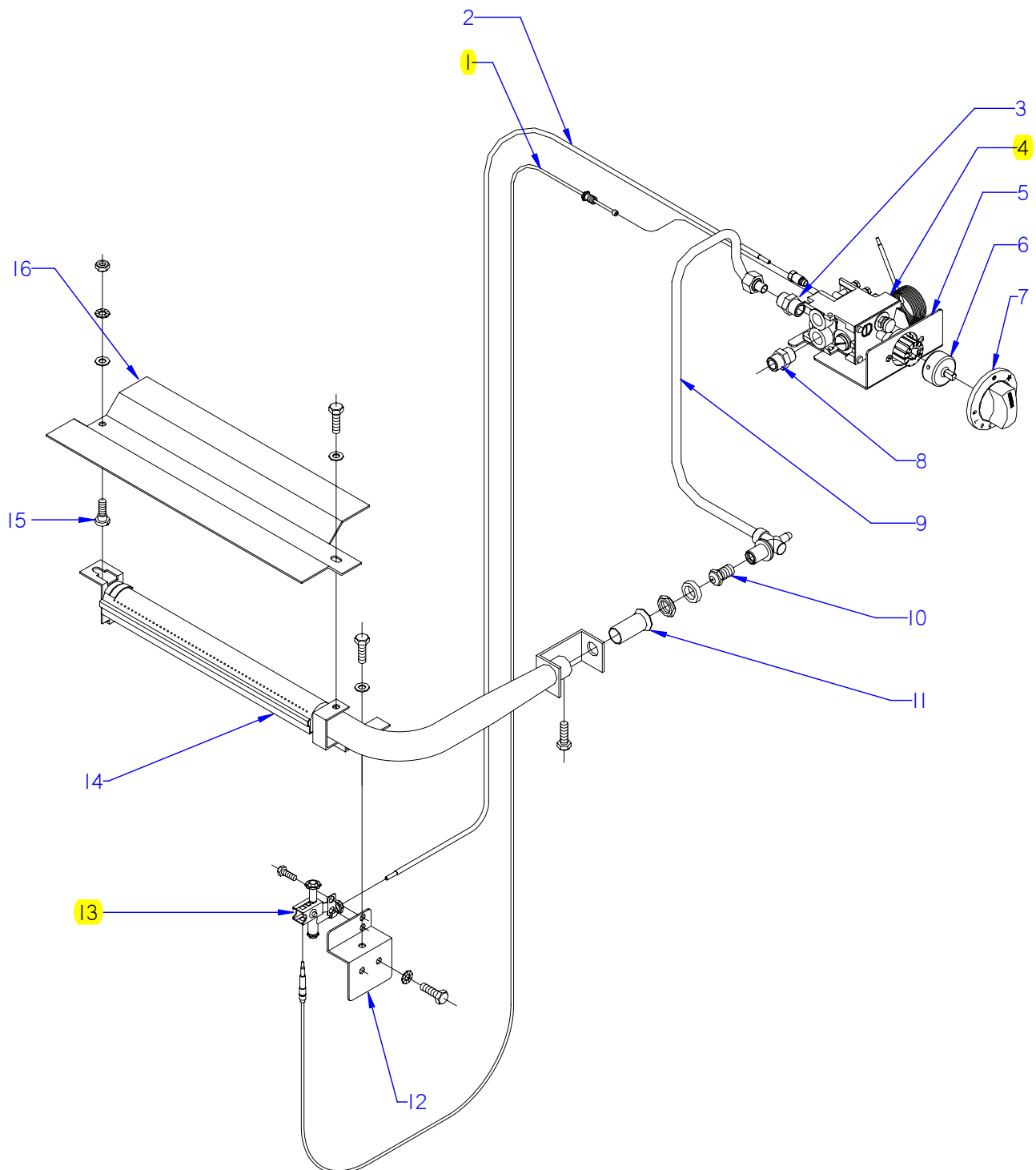

ITEM MARCADO EN COLOR = REPUESTO RECOMENDADO
 COLOURED ITEM = RECOMMENDED SPARE PART

N plano	Firma	Fecha	Aparato	CONJUNTO FUNCIONAL HORNO / FUNCTIONAL SET OVEN	Lamina	
C-2704	<i>[Signature]</i>	2010-10	COCINAS SNACK	5		

COCINAS SNACK /SNACK RANGES

ZONA / ZONE

CONJUNTO FUNCIONAL HORNO
FUNCTIONAL SET OVENPLANO
DIAGRAM

C-2704

ITEM	CODIGO CODE	DENOMINACION	NAME	CAG-21	CAG-31						
1	U562130000	TERMOPAR L=850	THERMOCOUPLE L=850	1	1						
2	U505081000	TUBO PILOTO	PILOT PIPE	1	1						
	U134323000	RACORD BICONO 6 958.031	BICONE CONNECTION 6 958.031	1	1						
3	R155068000	MANGUITO 3/8"	HOSE 3/8"	1	1						
4	T982100000	VALVULA 630 EUR 630.343	VALVE 630 EUR 630.343	1	1						
	T982102000	TAPON 3/8 972.061	CAP 3/8 972.061	2	2						
	Q306058000	ARANDELA 23,5X17,60X1,5	WASHER 23.5X17.60X1.5	2	2						
5	U505080000	SOPORTE VALVULA DE GAS	GAS VALVE BRACKET	1	1						
6	U842100000	SUPLEMENTO PARA EUROSIT	SUPPLEMENT FOR EUROSIT	1	1						
	Q131502000	VARILLA ROSCADA 5X6	THREADED ROD 5X6	3	3						
7	U502134000	BOTON DE MANDO Ø 8	CONTROL BUTTON Ø 8	1	1						
8	U875017000	MANGUITO R 3/8"-R1/2"	HOSE R 3/8"-R1/2"	1	1						
9	U505078000	CONDUCCION QUEMADOR COM.	COMP. BURNER PIPE	1	1						
	Q153002000	TORNILLO TAPON	CAP BOLT	1	1						
10	U012401000	TOBERA DE Ø 1.15 B.P.	NOZZLE Ø 1.15 B.P.	1	1						
10	9429400000	TOBERA DE Ø 1,80 G.N.	NOZZLE Ø 1.80 G.N.	1	1						
	Q301323000	ARANDELA 25X17X6	WASHER 25X17X6	1	1						
	Q223019000	TUERCA 3/8 GAS LATÓN	NUT 3/8 GAS BRASS	1	1						
11	U325707000	REGULADOR AIRE (QUEMADOR)	AIR CONTROL (BURNER)	1	1						
	Q012031000	TORNILLO EXAGONAL M5X10	HEXAGONAL BOLT M5x10	1	1						
12	U505630000	SOPORTE PILOTO HORNO	OVEN PILOT SUPPORT	1	1						
	Q012041000	TORNILLO EXAGONAL M6X10	HEXAGONAL BOLT M6x10	2	2						
	Q242040000	ARANDELA ABANICO A6 A.304	FAN WASHER A6 A.304	2	2						
	Q232040000	ARANDELA A6	WASHER A6	2	2						
13	11U4421340	PILOTO	PILOT	1	1						
	U442137000	INYECTOR Ø 0.4 GN	INJECTOR Ø 0.4 GN.	1	1						
	Q012021000	TORNILLO EXAGONAL M4X10	HEXAGONAL BOLT M4x10	2	2						
14	U505730000	QUEMADOR COMP.HORNO M-310	OVEN COMP. BURNER M-310	1	1						
15	R252624000	PITON SOPORTE	SPIKE SUPPORT	1	1						

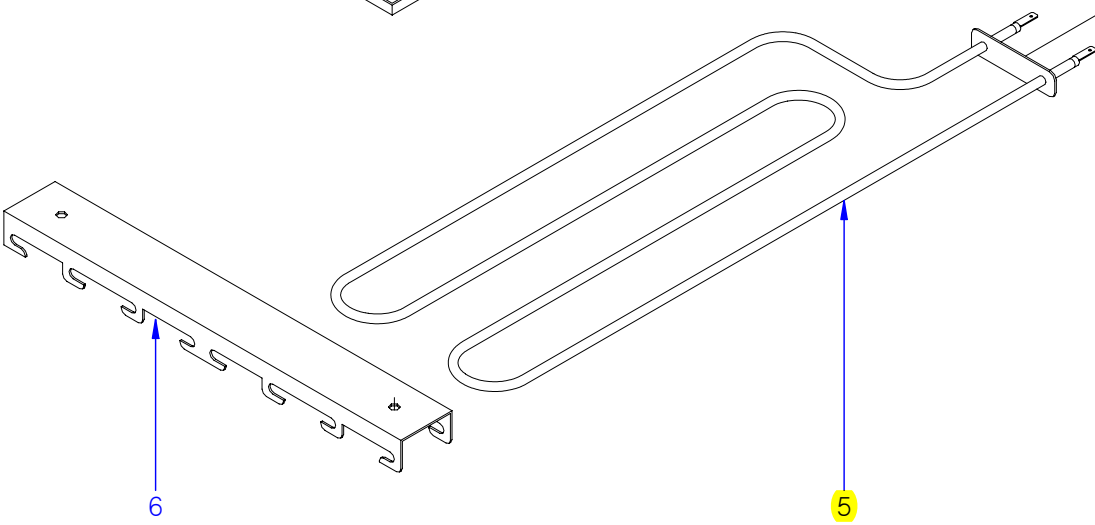
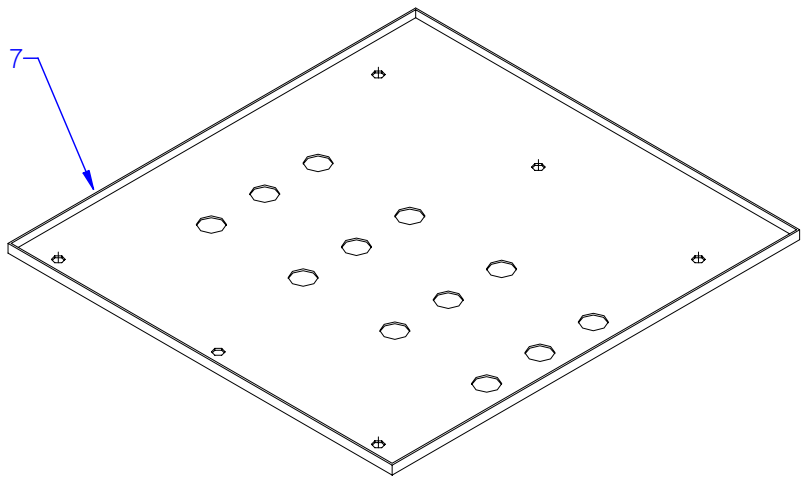
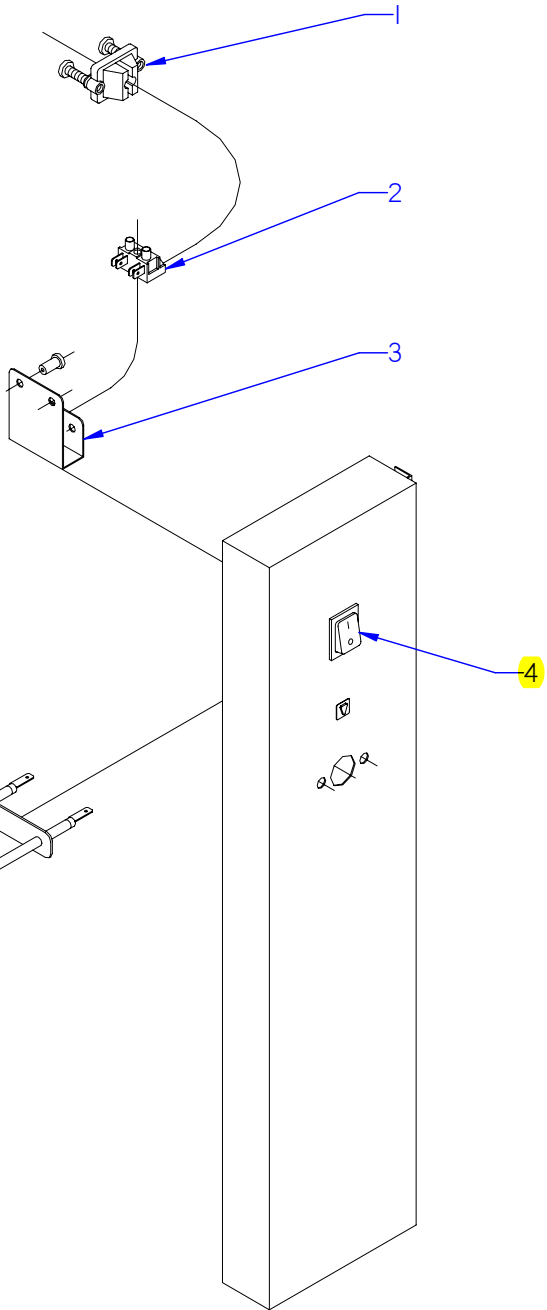

ITEM MARCADO EN COLOR = REPUESTO RECOMENDADO
 COLOURED ITEM = RECOMMENDED SPARE PART

N plano	Firma	Fecha	Aparato	Lamina
C-2705	<i>[Signature]</i>	2010-10	CONJUNTO FUNCIONAL GRILL / FUNCTIONAL SET GRILL COCINAS SNACK	6
asber				

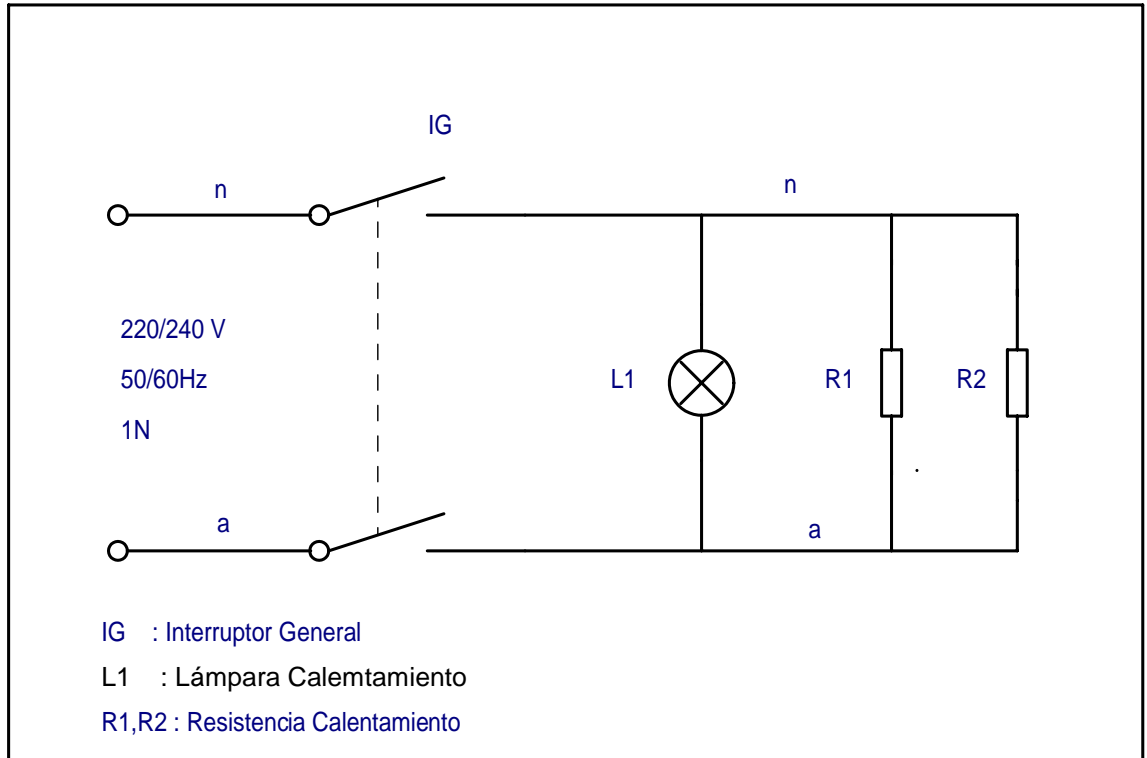

	Esquema electrico		Papel	U503020		
Nº	Pieza	Cant.	Material	Nº Clasificacion	Acabado	
Nº	Modificacion		Propuesta de	Fecha	Tolerancias generales	
					$\leq 5 \pm$ 50-100± : 5-25± > 100± 25-50± ±	
	Firma	Fecha				Mecanizado superficial
Dibujado	Plazaola	05-01-2000				
Proyectado						
Comprobado						
Escala	COCINAS CAFETERIA GRILL				Plano numero	HB-71538
	Plano hau ez daiteke erabil ez berrizta gure baimenitz gabe				Sustituye al Nº	
					Sustituido por	

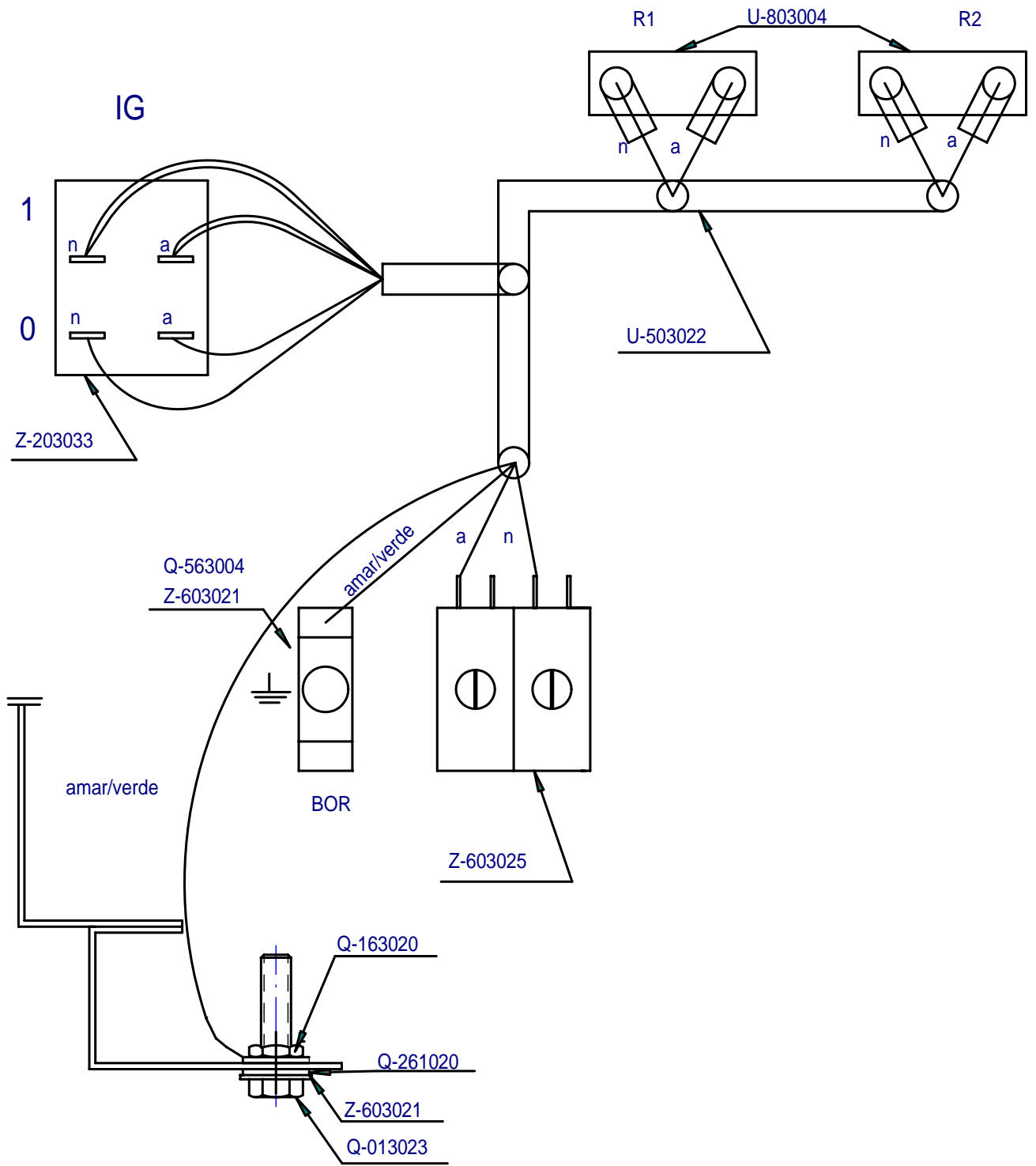

Plano de montaje				U503021		
Nº	Pieza	Cant.	Material	Nº Clasificación	Acabado	
Nº	Modificación	Propuesta de		Fecha	Tolerancias generales	
					$< 5 \pm$ $50-100 \pm$: $5-25 \pm$: $> 100 \pm$ $25-50 \pm$: \pm	
Dibujado	Firma	Fecha				Mecanizado superficial
Proyectado	Plazaola	10-01-2000				
Comprobado						
Escala	COCINAS CAFETERIA GRILL				Plano numero	HB-71541
	Plano hau ez daiteke erabil ez berrizta gure baimenitz gabe				Sustituye al Nº	
					Sustituido por	